

INSTALL DWG

TOWN AND PARK FURNITURE



MB120/CL 'CBD' MOBILE BIN ENCLOSURE (surface mount only)

Install mobile bin enclosure in accordance with the notes below. For important details on expansion and chemical anchors see **anchoring recommendations**. *NOTE: Correct door operation relies essentially upon a true level concrete surface plane being established:

- 1 A** Install unit direct to existing level concrete pavement (where suitable) **or**
- 1 B** Install unit on a level concrete base* ensuring door-side edge finishes flush with adjoining pavement.

*Suggested minimum concrete base for **MB120/CL**: 640 x 640 x 150 (D) **subject to on-site ground conditions**.

NOTE: On rising ground lift base level to suit, and blend pavement surfaces to footing edges. Install unit with door facing down slope to prevent fouling during opening.

- 2** Install unit using 4 **stainless steel** 12mm chemical or expansion anchors with 75-100mm penetration into concrete. Use **stainless steel** washers as shims if required to ensure accurate base level.



MB120/CL/A/ASH

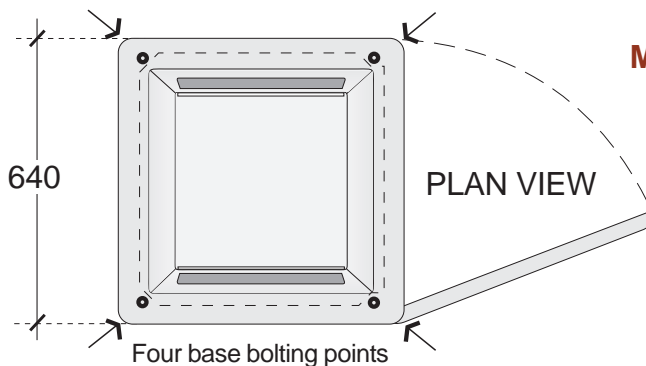

MB120/CL (/ASH) Mobile bin enclosure (120 litre capacity)

NOTE: SECURE FINAL TENSIONING OF ALL BOLT-DOWN POINTS WILL ESTABLISH RIGIDITY TO THE ENTIRE BIN UNIT.

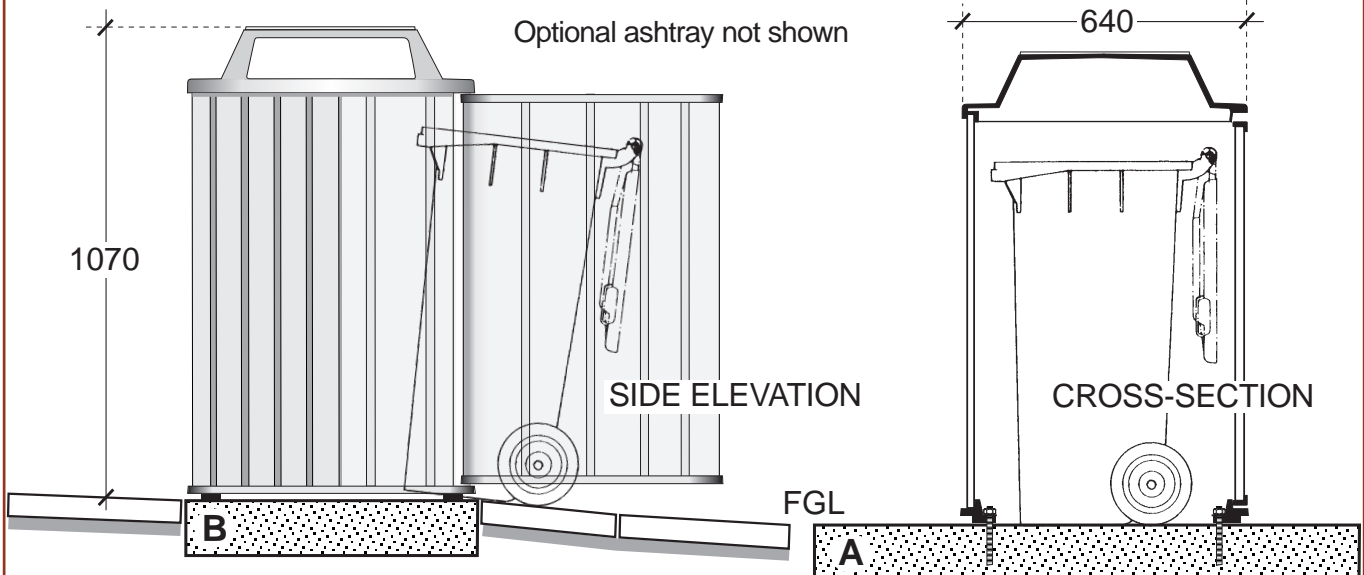

NOTE: Install unit with door facing down slope to prevent fouling during opening.

LAST UPDATED: 8.05



ANCHORING RECOMMENDATIONS:

Town and Park Furniture recommends the use of **stainless steel** masonry anchors ONLY, with chemical or expansion anchors being the preferred methods.

The following anchor installation summary gives recommendations re hole preparation, anchor installation and securing of the fixture: ***Do not exceed the max. stud size recommended for each product type as socket access may be limited within integral boltholes recesses. Refer to individual product install drawings for max. stud size recommendations:**

1. TYPICAL HOLE PREPARATION:

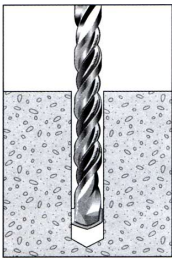

Drill hole using correctly sized rotary hammer carbide bit to the specified depth in solid substrate.

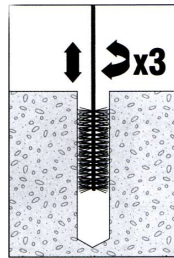

a) Clean hole with correct size hole cleaning brush with stiff nylon or wire bristles. Using a push/pull and twisting motion, ensure the sides of the hole are scrubbed at least 3 times for full depth of hole.

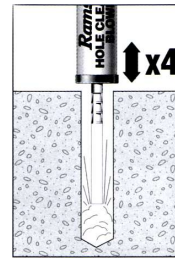

b) Remove debris, dust etc. from the hole using a hole cleaning blower with at least 4 swift pumps. Alternatively, a strong blast of compressed air may be used.

2. ANCHOR INSTALLATION:

EXPANSION ANCHOR

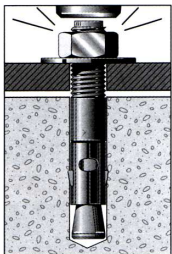

Insert anchor into hole flush against fixture.

CHEMICAL ANCHOR

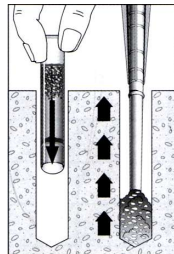

a) Insert correct sized chemical capsule or inject chemical mortar without creating air pockets in the hole.

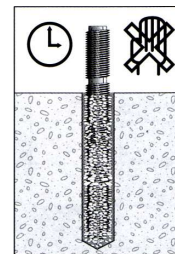

b) Drive stud to bottom of hole. Do not move the stud while chemical mortar is curing. See manufacturers data for setting times.

3. SECURING THE FIXTURE:

EXPANSION ANCHOR

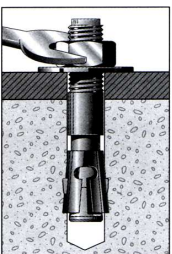

Tighten with a spanner. For optimum anchor performance use a torque wrench.

CHEMICAL ANCHOR

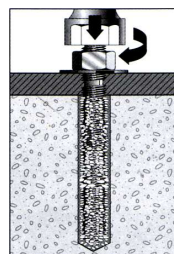

Attach fixture and tighten nut in accordance with recommended tightening torque.

The above anchor installation summary has been kindly provided by: RAMSET Fasteners (Australia) Pty Ltd. For further information including full technical data sheets visit..... www.ramset.com.au